

HAMILTON™

RANGEMASTER AM1000

Multiple Transmitters to cover more area

Section 1: Sync only the audio (Zerobeat)

Section 2: Sync Radio carriers and Audio

Section 1: Sync only the audio (Zerobeat)

- 1.1 The Basics Page 2
- 1.2 Syncing and Phase Flutter Page 2
- 1.3 Audio sync methods Page 3
- 1.4 Conclusion Page 5
- 1.5 Troubleshooting Page 5

Section 2: Sync Radio carriers and Audio

- 2.1 The basics Page 6
- 2.2 Practical descriptions Page 6
- Slave / Master wire diagram Page 7
- 2.3 Transmitter placement Page 8
- 2.4 Installation & Cabling Page 9
- 2.5 Tuning Page 9
- 2.6 FINAL TUNING / PHASING Page 10
- Voltage Drop Reference Chart Page 11
- 2.8 Audio matching Page 15
- 2.9 Final Notes Page 15

- 2.10 Trouble shooting Sync Radio carriers and Audio Page 17

A multiple transmitter installation can employ either of these methods, or may even be a combination of both methods.



RangeMaster Transmitters, Inc
(919) 362-9393

Copyright 2010 All Rights Reserved

Section 1: Sync only the audio

1.1 The Basics

Syncing just the audio method (Zerobeat) is the most commonly used method or system. It is the most economical usually, though the system used can depend on the need and situation the technician is facing.

Placement of the individual transmitters is critical for proper area coverage. A common mistake is to (assume) each transmitter will get some guessed amount of range, then using a map place the transmitters, or find installation sites blindly.

The proper way to place the transmitters is to develop a sense for how much range you will be getting for each site. This may involve some trial installations. Different locations and grounds will give different results. The other installation manuals relating to single installs can be referenced.

Once you have an idea what sort of range to expect you can pick your install sites. Realistically we cannot always have the perfect sites we want, availability is an issue, but the goal is to place the transmitters so that strong signal does not overlap. Not only does this waste potential coverage area but it can be a source of (phase flutter see 1.2). Sometimes you can trade services for a install space. For example a customer had agreed to broadcast information for a local library in exchange for their permission to place a transmitter on their roof.

Don't space the transmitter too far apart either, or you will have "dead" areas where people will not be able to listen. If you wind up with a dead area, it can be possible to add in a transmitter using the other "sync rf carrier and audio" method, to fill in the hole.

1.2 Syncing and Phase Flutter

With the Zerobeat method you are syncing the audio, as long as any delay is within a tenth of a second or so there should not be noticeable echo. See the different Audio Sync methods in Section 1.3. Internet is the method that is most difficult to control the delay, however the Barix (Barix.com) device is successfully used by most.

The radio carriers will not heterodyne, or "fight" each other because the transmitters are crystal controlled. This is why we make two versions of the transmitter,

A crystal controlled version AM1000C and a agile version the AM1000A (frequency set with switches) The AM1000C crystal version has a tighter frequency tolerance. You should only use the AM1000C model for multiple transmitters systems. If you have a AM1000A it can be converted to a AM1000C with a simple kit.

There is also an adjustment on the unit, that will “pull” the crystal frequency slightly. C28 near the crystal will trim the frequency should the need arise. If you are getting some heterodyning, or what will sound like a very low “growl”, you will need a frequency counter to set the transmitter to exact frequency.

Attach the frequency meter to one of the pins on the Phase Delay J10 Jumper block. Be careful not to short out any of the pins. Connect the ground lead to the Test hole GND. Adjust C28 to read the desired frequency exactly to the hertz. Be sure to get a frequency meter that is capable of reading the frequency to the hertz (7 digit). Then set all transmitters in the system to this same frequency.

Even if there is no heterodyning, the “phases” of the different radio carriers are not synced with the method and will be free running against each other. This is the source of any potential “phase flutter” The flutter will only be noticed if you get the radio carrier fields to close together. What you want is the signal from transmitter A to just start to weaken, then the signal from transmitter B starts to become strong. If this is the case any flutter should not be noticeable.

1.3 Audio sync methods

Getting audio from one place to another is a problem lots of people have to solve. Radio stations need to move audio from the studio to a remote transmitter, or from a remote site to a studio. Businesses often need remote audio or data links. This is a STL or studio link. Possible ways are:

- Microwave
- Telephone line
- Internet
- Special FM radio sub carrier
- Other radio transmitters

Microwave can be difficult and expensive. First you need the two sites you want to connect to have line – of sight for the microwave antennas to “see” each other.

Careful alignment and objects in the way can be challenges. If the manufacturer advertises 4 mile range count on it only for about half that. Usually the advertised range is only for perfect optimal conditions.

<http://prairietech.us/> has an inexpensive Part 15 microwave system

Telephone line was the most common method used before Barix came out with a system that made the Internet workable. See the diagram. The advantage of the telco line is no sync problems. Pricing for a Telco link will vary widely depending on where you are.. We have seen it actually be cheaper than Internet, but then in other areas it was quoted ridiculously expensive. A nice feature of the Telco connection is the line would be 600 balanced in/out. This matched the transmitter. You would simply feed the 600 line with your audio signal at the studio, at the transmitter site a balanced pair would be connect directly from the Telco connection to the AF+ and AF- terminals on the transmitter, very simple.

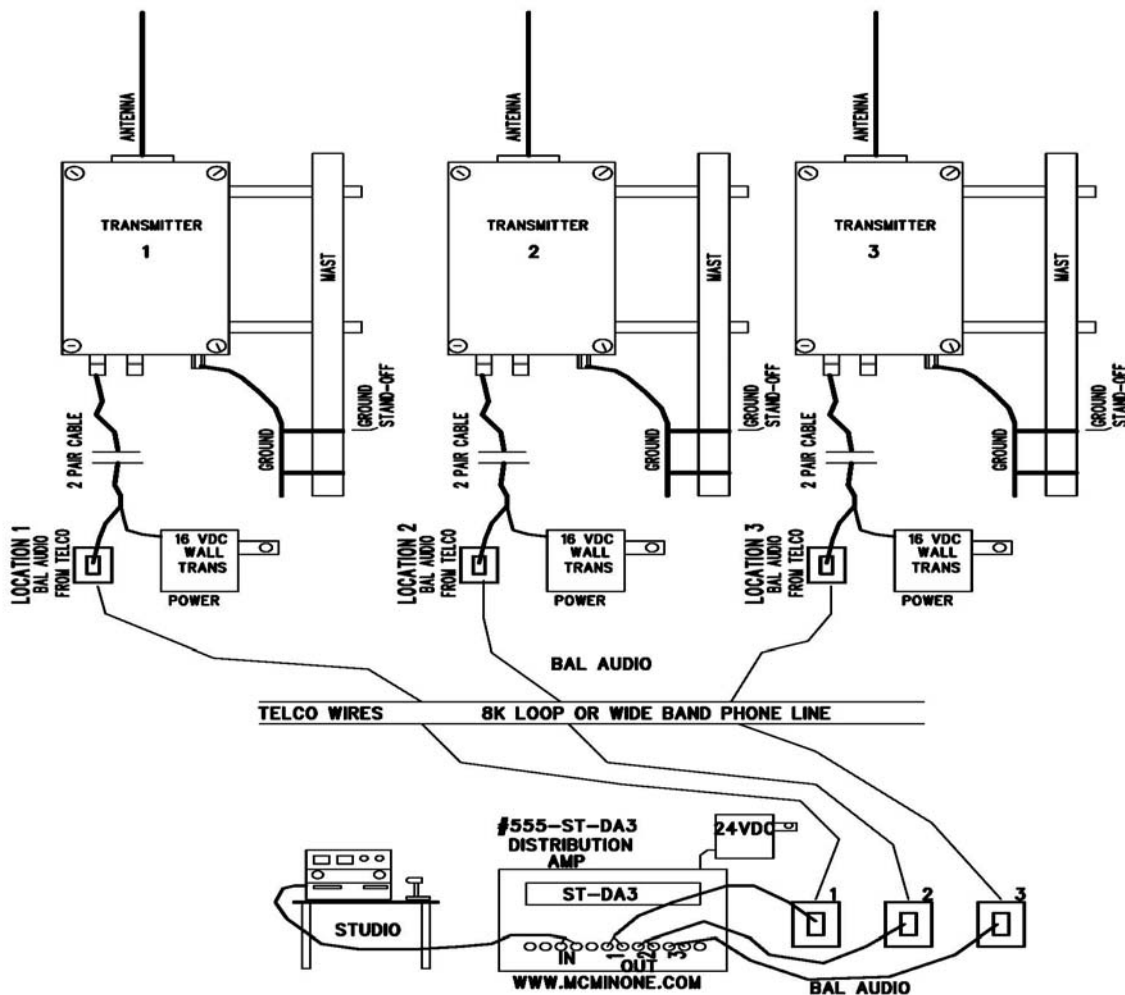

Internet

This is the most commonly used method. Sometimes an Internet connection will already exist at the location. The trick is to control the sync. Barix seems to do a good job of this, contact them with specific questions about their Internet links. You need the model 100 Instreamer and Exstreamer.

<http://www.barix.com/>

The Instreamer sends the data and the Exstreamer receives the data. It seems you can stream to up to eight boxes at a time.

FM radio sub carrier is a great way to distribute an audio signal if you can afford it. FM radio station can broadcast additional audio channels. These are used for stock market quotes, data, blind reading service, ect. This can be expensive.

There are other radio links available on the market, most are fairly short range.

1.4 Conclusion

Zerobeat is simply setting up an individual transmitter, you can use the information designed for individual transmitter use for most of the process. The difference comes into play when you are connecting the audio to the different sites, placing the multiple sites, and troubleshooting any heterodyne issues.

1.5 Troubleshooting

If you are getting a “growl” or heterodyne try to set your frequency using C28 with a frequency counter as described in section 1.2

If your audio sounds “funny” try reversing the polarity.

If you are getting a “zone” of “flutter” directly in-between the transmitters this may be phase flutter, you may have your transmitters too close together and are overlapping strong signals. In most cases any phase flutter is not noticeable, but if it is bad you can reduce power to lessen it.

If you are getting audio echoes you need to work on getting your audio sync better, be sure to use the Barix device if you are using the Internet.

Section 2: Sync Radio carriers and Audio

2.1 The basics

The RangeMaster was originally designed to be a "highway transmitter", used to cover a highway with an AM band signal. A transmitter is placed every 1/10 or so down the highway, and the transmitter radio carriers and audio is synced by wire that would be installed underground. This achieves continuous coverage of the highway. However the transmitters are not intended to be installed very close to each other, for example inches apart. The intention is to install them far apart, for example around a shopping mall, or at the corners of a large building.

2.2 Practical descriptions

Again these installs are similar to a individual installation, you can use the individual install manuals for reference. The difference will be in the final phasing and tuning, placement of the transmitters, wiring.

To add an additional slave to the first (master) transmitter simply wire the second terminal block to one of the terminal blocks in the second (slave) transmitter. See diagram. All additional transmitters are wired the same way. You need to use twisted pair wire for the audio and sync signal. The sync signal should not be longer then 1500 feet without an amplifier. Even though the sync is conventional RS485, do not use off - the - shelf RS 485 amplifiers, the sync does not contain information this equipment will be looking for. Contact us for the amplifier.

The audio does not have a length limit. If you are running long lengths of cable, be aware that nearby lighting strikes can induce a high voltage into improperly installed or ungrounded long cables. Of course the cable should be shielded.

A concern is sending the power to each slave without to much voltage drop. See the chart for approximate voltage drop for a given length of wire. If your voltage drop is going to be to high, you will need to install a separate power supply close to that slave, or run a separate larger power wire.

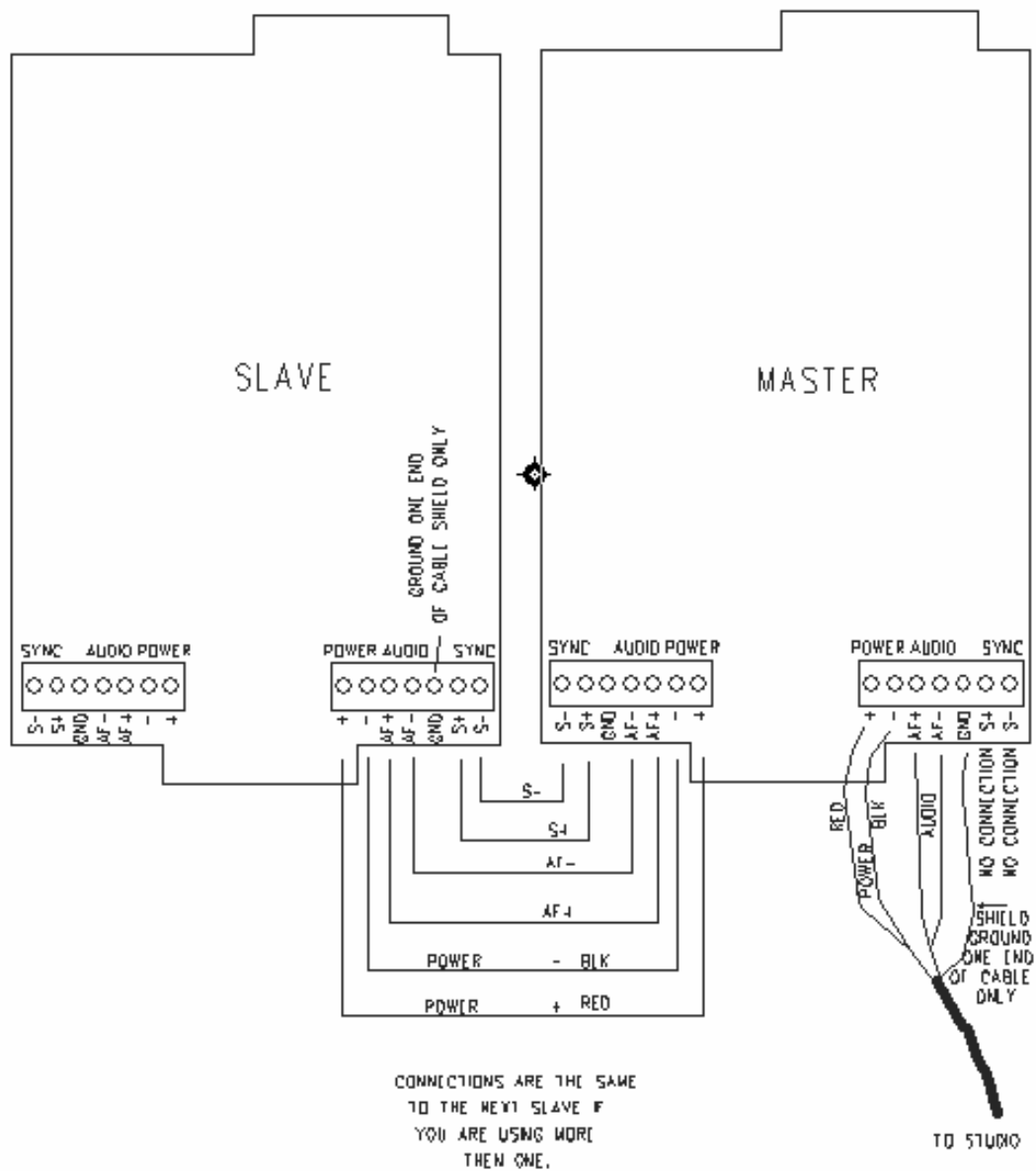

Slave/Master wire diagram

2.3 Transmitter placement

The Sync Radio Carriers and Audio option works well if you have plenty of room on a installation site, and the opportunity to connect/install the connecting wire. If the wire is not very long, it is possible to use 3 pair wire. A pair for audio, a pair for the sync, and a pair for power. However if the cable gets so long that voltage drop becomes a problem, you can use 2 pair wire leaving the power pair out. Then use a power supply close to the slave transmitters instead of connecting power in the cable.

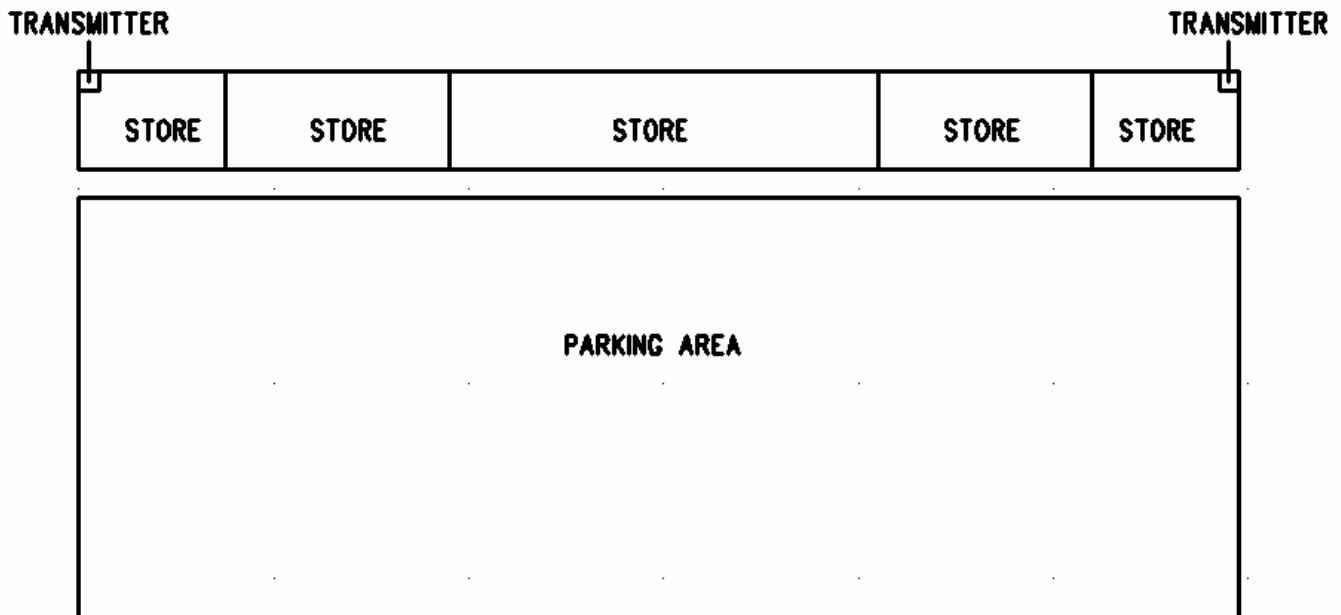

The diagram above shows two transmitters on a strip shopping center. The Master on the left is connected to the Slave on the right by 3 pair wire. The two transmitters will cover more area than one transmitter. Because of the sync connection, the transmitters will not heterodyne, or “fight” each other. And there is no problem with audio sync since the audio is connected by wire. In this case power could probably be connected by wire as long as the wire was #22 or larger.

2.4 Installation & Cabling

First install all of the transmitters. Refer to manual concerning the installation of single transmitters.

Complete the wiring as shown on the diagram on page 7. The two terminal blocks in the transmitter are the same. Be sure to “double check” your wire cabling work. A common problem is to “mix” the return or part of the pairs for the power, audio or sync, if this happens things will not work. The wiring must be correct. Simply connect the Sync + & - , audio AF+ & AF-, and power + & - signals to the same terminals on the next transmitter. You are connecting these same signals to all the transmitters. Be careful to keep the + & - polarities correct.

If you are going to use any individual power supplies at any of the transmitter location, install those and connect.

Pick one transmitter to be the master. It should be the first transmitter in the “chain”, the first transmitter the wire from the studio connects to. The “wire chain” starts at the studio and ends at the last slave transmitter.

Locate the J9, 3 pin jumper on the transmitter board, it is in-between the crystal and nearest heat sink. On the Master transmitter place this jumper in master mode by moving the jumper shunt to “master” position (marked on the board) , and on the Slave transmitters place this jumper on the “Slave position, as marked on the board. This will tell the transmitter whether to send a sync signal or to receive one. Do not turn on the power with this jumper in the wrong position. If your cable is long, place a shunt in the J7 jumper (between the two heat sinks) of the last Slave transmitter the cable connects to, or the last unit in the chain. This enables a termination for the sync signal.

2.5 Tuning

FIRST TUNE MASTER

Turn all slaves off (locate on/off switch to bottom of board). Follow instructions in the main tuning instruction manual to tune master. Once the Master is operating disable the Master radio output by removing the coil tap select shunt J6. These jumpers are located near the large red round coil. This will disable the RF signal but still allow the sync signal to be sent to the Slave / Slaves. Return this shunt to its original position after tuning the Slaves. Turn on each Slave on and tune up each Slave as a normal individual transmitter, one at a time.

2.6 FINAL TUNING / PHASING

Final tuning needs to be done with some sort of field strength indication. It is important to note that hooking a voltmeter to the transmitter power amp voltage (red and black) tuning method will not work when more than one transmitter is on. It has to be a field strength indicator of some sort. The further away the indicator the better. A oscilloscope with a length of wire on the input will suffice. Or simply use a voltmeter set to the lowest AC range. Spread the leads out and ground the black lead to the transmitter, the red lead is your antenna. Of course a field strength meter or a selective frequency meter approx. 1000ft away is best. Use Walkie Talkie's or a cell phone to communicate.

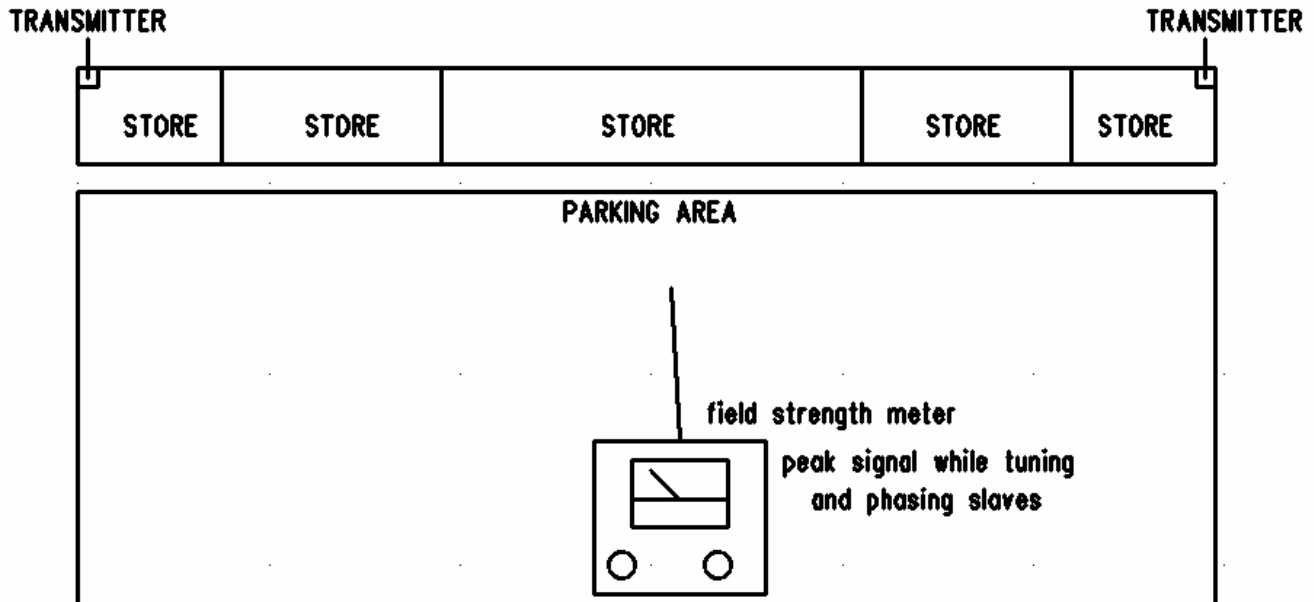

Be Sure you have reinstalled the shunt you removed from the coil tap select shunt J6 in the Master, in the same position you removed it from. Turn on Slave one, or the Slave if you have only one. You will want to adjust the Phase jumper shunt to the best position in each Slave, one at a time. Turn the Slave on, make the phase jumper adjustments, then turn the Slave off and move to the next Slave and do the same thing until you have phase adjusted all the Slaves.

Wire dis- Wire Wire dis- Wire dis- Wire Wire Wire dis- Wire dis-
 tance in distance tance in tance in distance distance tance in tance in
 feet in feet feet feet in feet in feet feet feet

Wire Size	Current in AMPS	Wire Ohms per 1000 Feet	Wire distance in feet							
			25	50	75	100	150	200	250	300
#24	0.1	25.7	0.1285	0.257	0.38589	0.514	0.77177	1.028	1.285	1.54819
#24	0.25	25.7	0.32125	0.6425	0.96471	1.285	1.92943	2.57	3.2125	3.87048
#24	0.5	25.7	0.6425	1.285	1.92943	2.57	3.85886	5.14	6.425	7.74096
#22	0.1	16.2	0.081	0.162	0.24324	0.324	0.48649	0.648	0.81	0.9759
#22	0.25	16.2	0.2025	0.405	0.60811	0.81	1.21622	1.62	2.025	2.43976
#22	0.5	16.2	0.405	0.81	1.21622	1.62	2.43243	3.24	4.05	4.87952
#18	0.1	6.38	0.0319	0.0638	0.0958	0.1276	0.19159	0.2552	0.319	0.38434
#18	0.25	6.38	0.07975	0.1595	0.23949	0.319	0.47898	0.638	0.7975	0.96084
#18	0.5	6.38	0.1595	0.319	0.47898	0.638	0.95796	1.276	1.595	1.92169
#16	0.1	4	0.02	0.04	0.06006	0.08	0.12012	0.16	0.2	0.24096
#16	0.25	4	0.05	0.1	0.15015	0.2	0.3003	0.4	0.5	0.60241
#16	0.5	4	0.1	0.2	0.3003	0.4	0.6006	0.8	1	1.20482
#12	0.1	1.59	0.00795	0.0159	0.02387	0.0318	0.04775	0.0636	0.0795	0.09578
#12	0.25	1.59	0.019875	0.03975	0.05968	0.0795	0.11937	0.159	0.19875	0.23946
#12	0.5	1.59	0.03975	0.0795	0.11937	0.159	0.23874	0.318	0.3975	0.47892
			Result in Volts	Result in Volts	Result in Volts	Result in Volts	Result in Volts	Result in Volts	Result in Volts	Result in Volts

Voltage Drop Chart

With this chart you can determine the approximate voltage drop in a given size of wire for a certain distance. For example a 25 foot section of two conductor wire (plus and minus) #24 would have a voltage drop of .1285 volt at the transmitter end. The chart takes into account the fact that the current actually travels 50 feet in a 25 foot section of two conductor wire.

Notice the voltage drop can become high, In 300 feet of #24 wire with .5 AMP flowing in it the drop is over 7 volts. So in this case if your power supply was 15 volts, you would only have less then 8 volts at the other end of the wire.

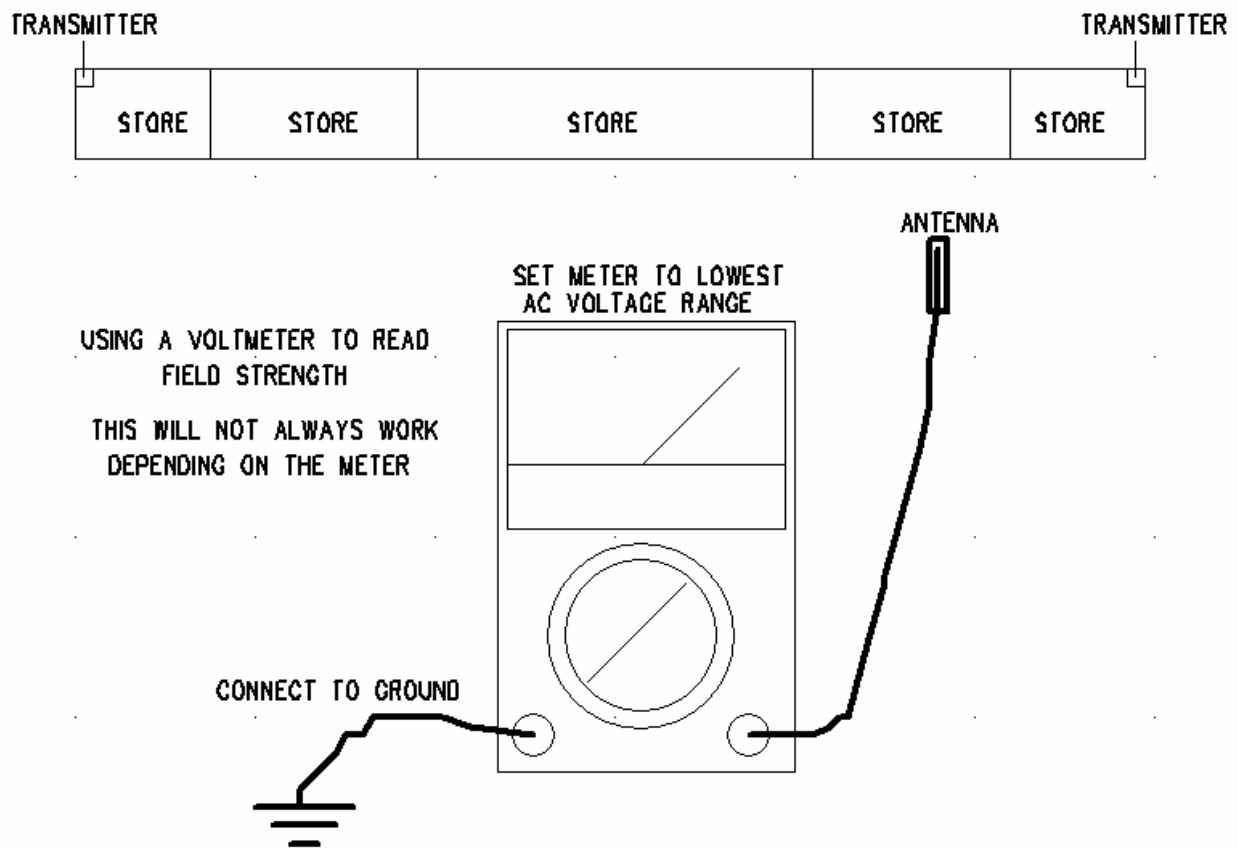

To adjust the phase there are 2 jumpers on the board that delay the signal phase by a jumper selectable time period. The job is to find the position of J10 and/or J5 (PHASE DELAY) (Positions 1-12 on the jumpers) on each slave that will best synchronize the radio carrier / or give you the highest reading on the field strength meter. Start with the Slave closest to the Master. If you use J5 leave the J10 jumper in the number 6 position.

In a pinch it can be possible to put somebody in a car about a mile away and talk to them (cellphone) while you make these adjustments, they can tell you if the signal is better/worse, but this will not result in the best tuned system. You really need some sort of field strength meter equipment.

If you can't seem to get anywhere try reversing the S+ and S- inputs to the slave. This will reverse the signal 180 degrees. Then start again with the jumper J5 and J10 positions. If you reverse the S+ and S- keep in mind it will affect the slaves further down the chain, you will need to re-phrase those if you have already phased them. Always start with the Slave closest to the Master.

The step on the phase delay is about 15 degrees.

Once you have found the position on J5 & J10 that seem to give the best field strength meter level turn that Slave off and move to the next Slave and do the same thing.

The default position for the shunt jumpers is position 0 At this position there is no phase delay

Look at the diagram to the right, as you can see each jumper setting delays the signal by 15 degrees. First adjust J10, then if it doesn't seem to peak the signal move to J5, leaving the shunt in J10 position 6. Each jumper block must have a jumper somewhere for the transmitter to work. If neither seems to get a peak then try reversing the S+ and S- wires to the terminal block.

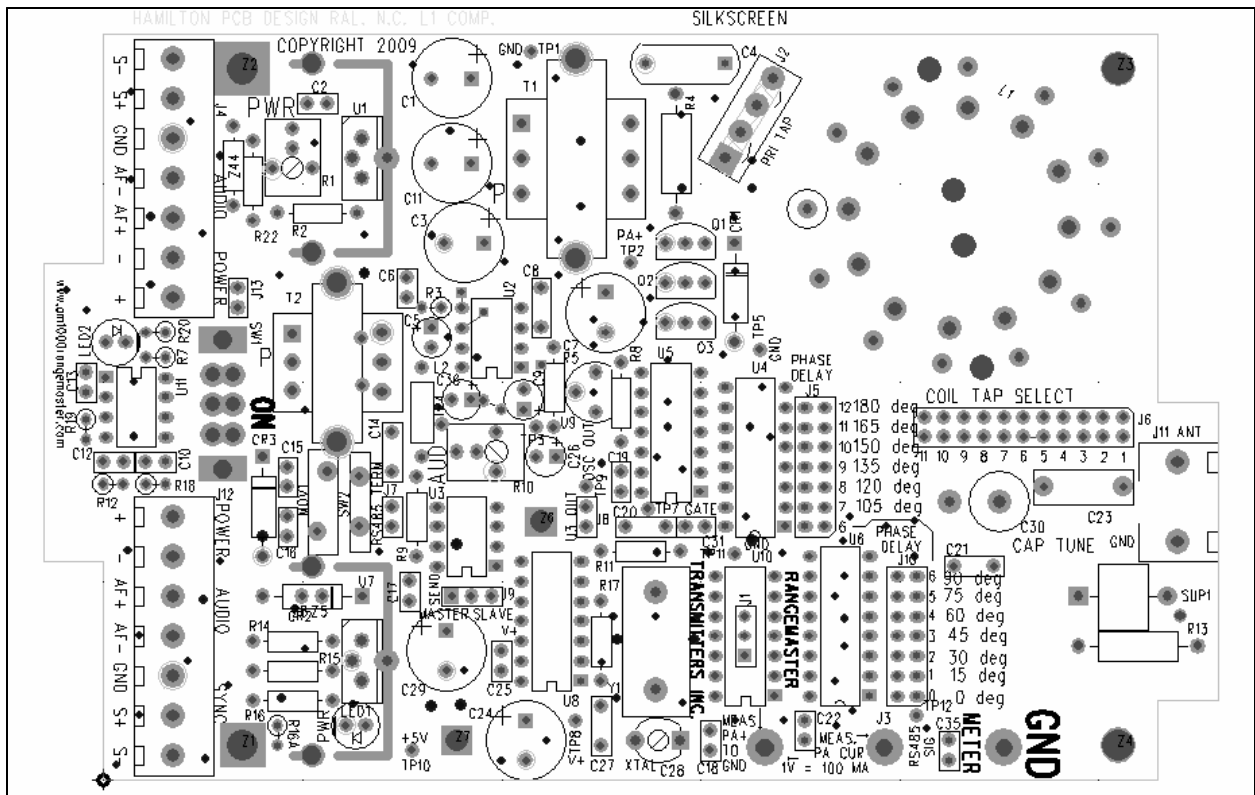
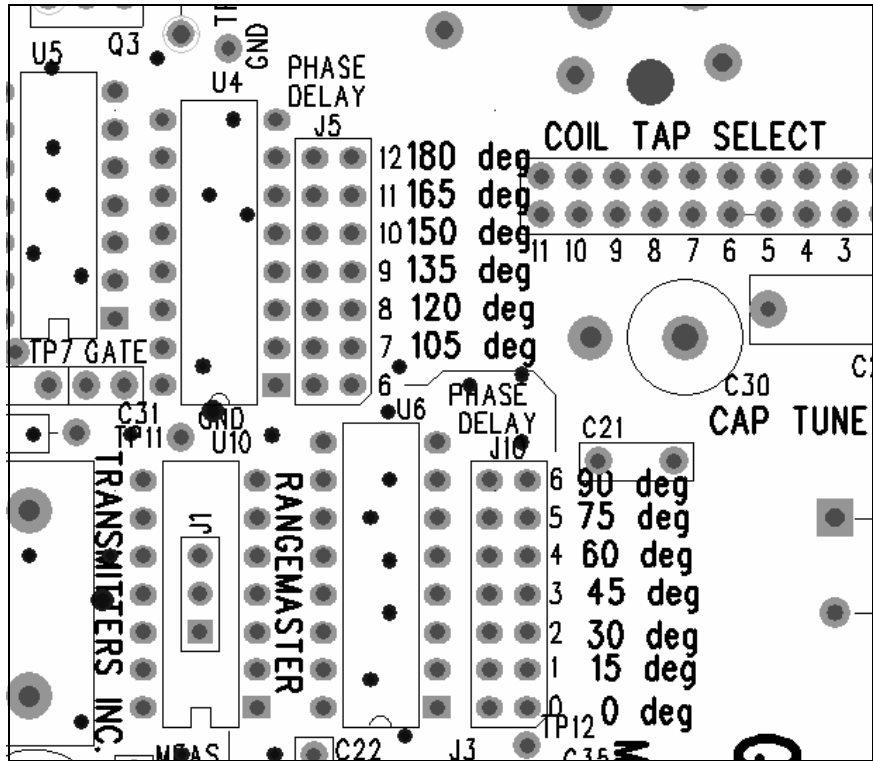

Once you have each slave working individually with the master, phased and tuned, it is time to turn on all of the transmitters at once.

Turn them all on.

It is a good idea to do a final tweaking if you have time, go back to each transmitter and be sure the CAP TUNE is set for best position, adjust it while watching the field strength meter to see if you can get any more signal from it.

Recheck the CAP TUNE adjustment and phase jumper shunt position for each Slave, also check the CAP TUNE for the Master.

You should not ever have to adjust the phase delay on the Master. Leave the phase delay at the default

J10 "0"

J5 "6"

Positions.

2.8 Audio matching

If you are driving many transmitters with a long balanced pair you may need to match the audio impedance properly. For example two 600 ohm audio loads in parallel would equal 300 ohms, this 300 ohm load would need to be matched to a 600 ohm output. This can be done by using (2) 150 ohm resistors as shown.

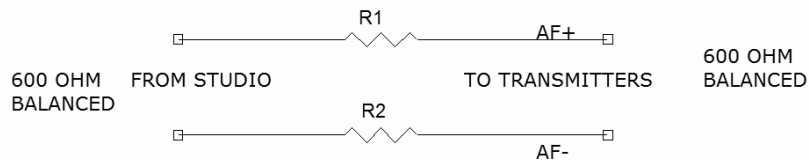

See the above diagram. The resistors will match the impedance to however many transmitters you are using, if you use the correct values.

- One slave use 150 ohm 1/4 watt or higher resistors
- Two slaves use 200 ohm 1/4 watt or higher resistors
- Three slaves use 220 ohm 1/4 watt or higher resistors
- Four slaves use 250 ohm 1/4 watt or higher resistors
- Five slaves use 250 ohm 1/4 watt or higher resistors
- Six slaves use 250 ohm 1/4 watt or higher resistors
- Seven slaves use 250 ohm 1/4 watt or higher resistors

As you can see once you get over 4 slaves adding more slaves does not change the impedance dramatically.

2.9 Final Notes

Total maximum spacing from the Master to the final Slave is 2000 feet (standard RS485 rules apply) unless you are using an amplifier. Each transmitter can have its own separate power supply. There is no limit on the audio line length since it is 600 ohm, (telephone line) Impedance. The idea is to place the units around a large building/shopping mall and connect the sync so there is no heterodyne and adjust phase so there is no phase cancellation or flutter. Be sure the audio is in phase (+ to + and - to -) or you can get some cancellation.

The phase adjust will affect the location where the signal is strongest, the radiation pattern is a complex pattern of adds and cancellations, depending on terrain and structures.

As of the writing of this document the FCC rules for clustering (multiple transmitters) are nonexistent, we know of no rules against multiple transmitters and have been told by FCC agents that they have no objections to it. We have been told by the FCC enforcement bureau that multiple transmitters placed around a shopping mall or other large building for example would be legal. Systems using multiple transmitters (for example along a highway) have been around for many years. But until multiple transmitters is addressed by FCC rules we can't guarantee that the FCC will not object to it. Rangemaster Transmitters Inc. sells its' transmitters to comply with FCC rules.

Here is a response from the FCC concerning the matter in 2006:

Response:

If the transmitter was certified under Section 15.219 of our Rules and is an unlicensed AM transmitter, there is no limit on the number of transmitters that may be installed and no minimum distance at which they may be spaced.

The RangeMaster was originally designed to be a "highway transmitter", used to cover a highway with an AM band signal. A transmitter is placed every 1/10 or so down the highway, and the transmitter carriers and audio is synced by wire. This achieves continuous coverage of the highway. However the transmitters are not intended to be installed very close to each other, for example inches apart. Installing the unit like this is a violation of the rules.

The idea is to space them far enough apart to achieve continuous coverage without exceeding the field strength that would emanate from one transmitter (in the area of that transmitter). If you are unsure what this means please call us.

2.10 Trouble shooting Sync Radio carriers and Audio

The most common problem is wiring errors, if the slaves are not working go back and double, triple check your wiring. Have somebody else do it also.

People sometimes have trouble finding a good field strength meter. A short wave radio that has the AM band and a good meter can work. A professional field strength meter is best of course, but a selective frequency meter can be bought on the surplus market (Ebay) for about \$200. A selective frequency meter is basically a radio with a calibrated meter.

As mentioned elsewhere, a distant listener can be used for feedback, though this method can give false results.

If you are having trouble, try to get the slave transmitter working individually first by disabling the master radio output (pull the Coil Tap select shunt on the Master). This will allow the Master to send the sync signal, while the Master will not produce a radio signal.

Then your Slave should tune up as an individual transmitter if it is receiving the sync signal correctly. You should do this if a Slave does not seem to be adding or syncing in properly.

If your audio is garbled when a Slave is switched on check the audio polarity

Check the power voltage at each transmitter to be sure there is enough voltage, the transmitter should have at least 10-12 volts.

Make sure J9 is set correctly

The S+ and S- is for the sync signal, + and — is for the power, some get those reversed.

Check the individual transmitter troubleshooting manual for some ideas if you are stuck.