

# USER GUIDE



## ANGRY AUDIO

**PHONE**

+1 (615) 763-3033

**WEB**

answers@angryaudio.com  
www.angryaudio.com

**ADDRESS**

128 HOLIDAY CT STE 118  
Franklin TN 37067 USA



## Failsafe Gadget

P/N 991009

## Welcome to the world of Angry Audio, home of the audio gadgets.

The audio world is filled with complex, high-tech gear. Much of it bristles with seductive shapes and eye-catching lights and displays, and all of it promises to make things sound better and open up new creative possibilities.

But in order for those products to shine, you still have to get the basics right and sweat the details. Good audio isn't made by one component. It's made by getting things right every step of the way, especially the little things.

Accordingly, every audio gadget – including the Failsafe Gadget – is designed to solve common yet critical problems, and are meticulously engineered with performance and longevity in mind to deliver pristine audio for many years.

## Our promise and guarantee.

We know you'll love your Failsafe Gadget, but the universe is a strange place, so it's always possible that you won't. That's why we give you 30 days to bond with your gadget. If the two of you can't get your chakras to align, we'll buy it back.

Plus, every gadget is warrantied to be free from defects in parts and workmanship for two full years after you purchase it. If a gadget fails within this time period, Angry Audio will, at its discretion, repair or replace it so long as you let us know of the failure within the warranty period and can provide proof of purchase in the form of a dated sales receipt. You can call us at +1 615-763-3033, or reach us online at [www.angryaudio.com/contact](http://www.angryaudio.com/contact).

## Making a good first impression.

When you unbox your Failsafe Gadget, we really hope it makes a good first impression and that you take a moment to appreciate the lengths we've gone to in order to create a "built for broadcast" product. All audio gadgets are over-engineered to provide long-term reliability and guaranteed RFI immunity.

Some of this is apparent - such as the rugged powder-coated steel chassis - but much of this goodness is invisible, like the premium components used in the audio path. Even if you can't see it, you'll hear it!

## A word or two about safety.

Most of this falls under the category of common sense, but the company lawyers started to visibly twitch when we suggested we didn't need to spell out the obvious. Besides, extensive testing with volunteer focus groups resulted in over 100% of the participants who got a user guide without safety instructions immediately plugging in the device and jumping recklessly into their (filled) bathtubs. After a few weeks of this, we grew concerned our customer base was eroding, so safety warnings it is.

Audio gadgets aren't meat slicers or TIG welders, but still, they are intended to be used by qualified personnel only. To avoid electric shock, do not open the unit or attempt to perform any servicing unless you are qualified to do so.



The Failsafe Gadget has internal 120VAC or 240VAC power supply. Hazardous voltages are present whenever the unit is plugged in and may still be present on certain components even when the unit is unplugged.

The power cord is the primary disconnect device and so the outlet providing power to the gadget should be easily accessible. In other words, make sure you can back out of making any bad electrical decisions by yanking the plug. Use only a properly grounded outlet for power. Do not cut the ground pin or use a ground-lifting adapter, and do not defeat the polarized plug. Do not overload outlets.

Do not expose your gadget to rain or moisture. Do not block any ventilation openings, as lack of airflow could damage the unit or create a fire hazard. Any electronic device can fail without warning; do not use this product in applications where a life threatening condition could result due to failure.

Do not buy candy for trick-or-treat that you yourself will not eat. Do not start saying things like, "When I was a kid..." – it's a slippery slope to Curmudgeon Town. Do not wear a black belt with blue polyester slacks – this is white-belt-only territory.

## Mounting your Failsafe Gadget in a rack.

The Failsafe Gadget sits on four rubber feet that ensure it won't scratch the zebra wood inlays on your antique mahogany desk.

If you prefer to rack mount your gadgets, you'll need the optional Rack Mount kit which allows one or two gadgets to be installed side by side in a standard 1RU rack space.

Each Rack Mount Kit consists of a custom rack panel with cut outs for all front panel controls and displays. A blank filler panel is also provided if you are mounting only one gadget.

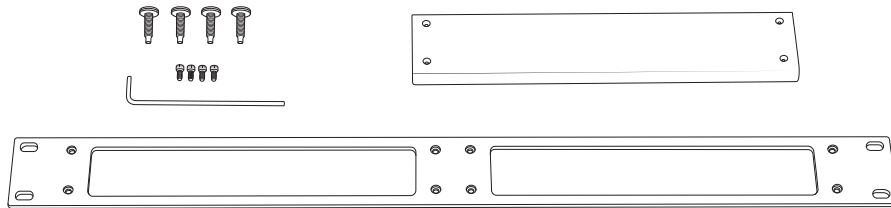

When rack mounting, remove the four rubber feet ("A") from the bottom of the gadget with a #1 Phillips screwdriver, being careful to save the screws.

Remove the four front panel 3/32" hex screws ("B"). You can rummage around your toolbox for your own hex key, or use the one we thoughtfully provide in the mounting kit.

Line up the gadget so that the holes exposed after removing the socket head screws line up with the mounting holes ("C") in the rack panel.

Attach the rack panel to the front of your gadget with the same screws you just removed. If you dropped one and it immediately rolled to an inaccessible location (as these things always do), don't panic – we've included spares in the kit.

Finally, use the provided rack screws (all four, please) to mount your gadgets.

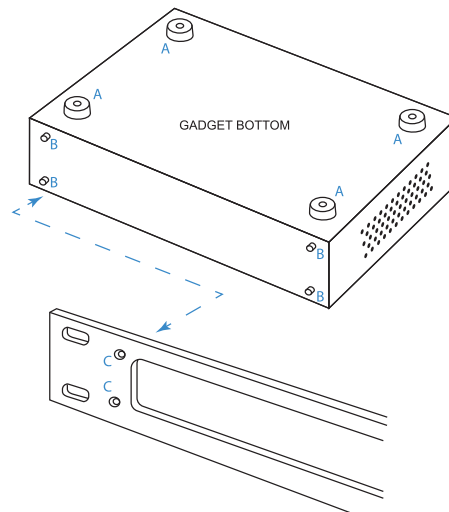

## Attaching your Failsafe Gadget to a wall.

If you prefer to secure your gadget to the inside of a rack, cabinet, or other flat surface, the optional Wall Mount kit comes in handy.

Each Wall Mount Kit includes two brackets, four No. 6 screws, and four cup washers.

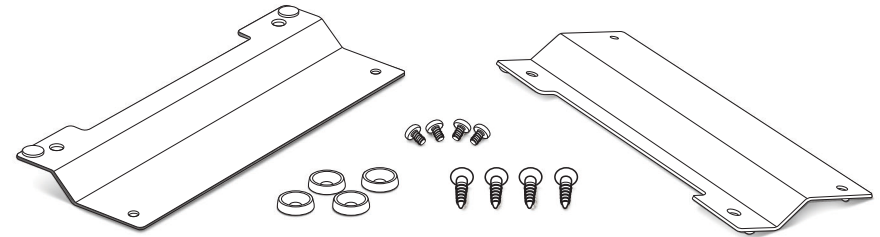

Remove the four rubber feet ("A") from the bottom of the gadget with a #1 Phillips screwdriver, being careful to save the screws.

Align the bracket holes with the holes in the bottom of the gadget, then attach the brackets using the screws removed from the rubber feet.

Use the four No. 6 screws ("B") and the four cup washers ("C") to secure the gadget to a plywood surface. Drilling pilot holes is recommended to reduce the risk of splitting the wood.

Different hardware (not supplied) will be required if you are mounting the gadget to a drywall (or other) surface.

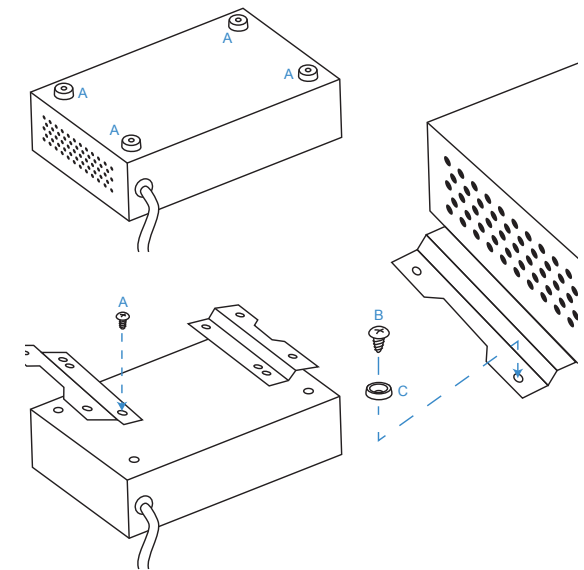

## Mounting your Failsafe Gadget under a counter.

Your Failsafe Gadget can be mounted under a counter, desk, or table using the optional Under Counter Mount Kit.

This kit includes two brackets, four No. 6 wood screws, and four cup washers suitable for mounting to a plywood surface. Different hardware (not supplied) may be needed if the mounting surface is a different material.

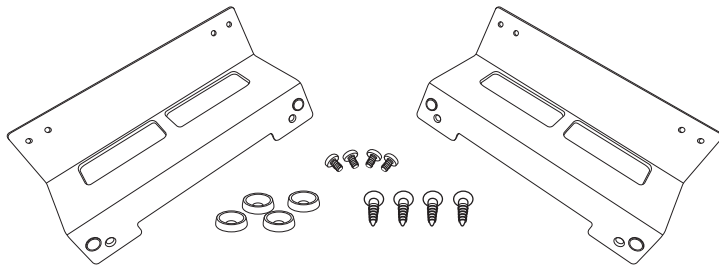

Remove the four rubber feet ("A") from the bottom of the gadget using a #1 Phillips screwdriver, being careful to save the screws.

Line up the brackets ("C") so that their mounting holes line up with holes exposed after removing the rubber feet. Orient the brackets as shown in the diagram to the right so that the deeper flat side supports the gadget and the "notched" side faces the under-mount surface.

Use the panhead screws ("B") removed from the rubber feet to secure the brackets to the gadget.

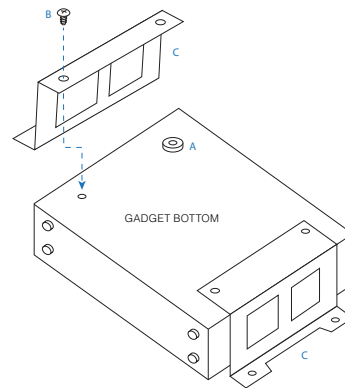

Use the four provided No. 6 screws ("D") and the four cup washers ("E") as shown in the diagram to the left to secure the gadget to the plywood underside of the counter, desk, or table.

Drilling pilot holes is recommended to reduce the risk of splitting the wood.

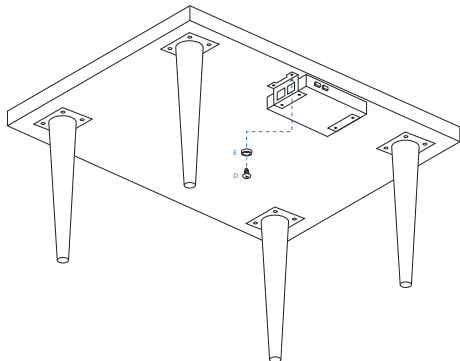

## Using your Failsafe Gadget on a desktop.

If you like the idea of using the Failsafe Gadget on a desktop but prefer a more permanent installation along with the convenience of having it angled up toward the user, we've got you covered with the optional Desktop Bracket Kit.

This kit includes two brackets, four No. 6 wood screws, and four cup washers suitable for mounting to a plywood surface. Different hardware (not supplied) may be needed if the mounting surface is a different material.

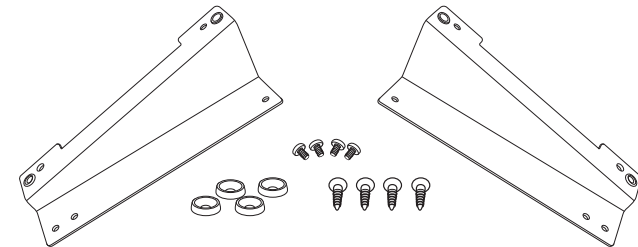

Remove the four rubber feet ("A") from the bottom of the gadget using a #1 Phillips screwdriver, being careful to save the screws.

With the bottom of the gadget facing up and the front panel facing toward you, line up bracket "C" with the holes exposed after removing the feet on the right side of the gadget. Orient the bracket as shown in the diagram to the right so that the flat side is attached to the gadget, and the "notched" side sticks up with the notch facing outwards. Use the panhead screws ("B") removed from the rubber feet to secure the brackets to the gadget.

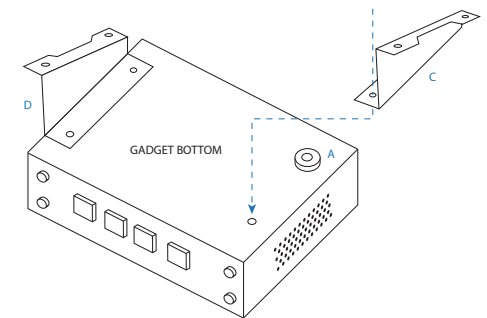

Use the four provided No. 6 screws ("E") and cup washers ("F") as shown in the diagram above to secure the gadget to a plywood surface.

Drilling pilot holes is recommended to reduce the risk of splitting the wood.

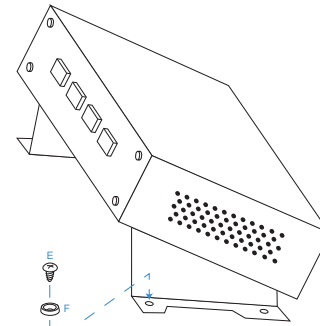

## The most dreaded words in radio...

There are a host of things that can induce panic at a radio station. A dip in the ratings. The espresso machine in the break room taking a dirt nap. Someone from sales driving the engineering van. A promotions event involving a helicopter and turkeys. But none quite as chilling as the words "Dead Air."

Dead air can result from malfunctioning equipment to air talent getting locked out of the building after a botched attempt at a convenience store run. Regardless, dead air almost always occurs in the dead of night, and we thought it would be nice to have a way to deal with these off-air emergencies without being dragged out of a warm bed. Enter the Failsafe Gadget.



t

At its core, the Failsafe Gadget is a stereo A/B switch - but with an important twist. When it detects silence on its primary input, it automatically feeds its output with audio from a secondary input such as a looping CD player, a portable music player, or a backup automation computer. You decide what threshold constitutes silence, how long the gadget waits before switching sources, and whether or not it switches back to the primary source by itself when audio is restored. It can even start the backup audio source or trigger an alarm when silence is detected.

In the event of a power failure, a relay bypass circuit routes the backup audio to the output (as a loss of power to the Failsafe Gadget likely means a loss of power to the main audio source). Be sure your backup source is fed from a UPS or a different circuit to take advantage of this feature.

Alternatively, you get set up the Failsafe Gadget so that the presence of a signal (rather than the absence of one) sets things into motion by feeding the primary audio into the B input and routing the override audio into the A input. When audio appears on the (normally quiet) A side, it interrupts the B side audio. When the A side goes quiet, the B side once again feeds the output. This can be useful for inserting emergency audio or for interrupting regular programming from a remote event during unattended operation.

Of course, you can bypass the sensor and manually switch between two audio sources for programs that only need automatic switching during unattended segments with either the front panel buttons or remotely using the logic port.

## Failsafe Gadget set up to replace missing audio.

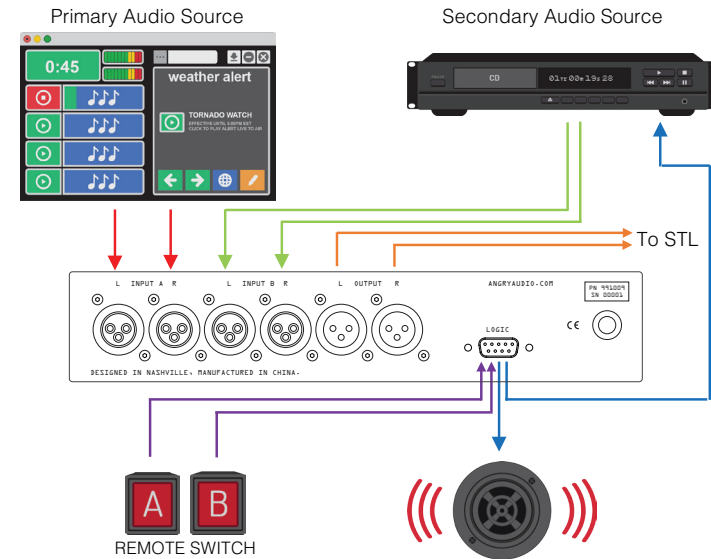

## Failsafe Gadget set up to insert external audio.

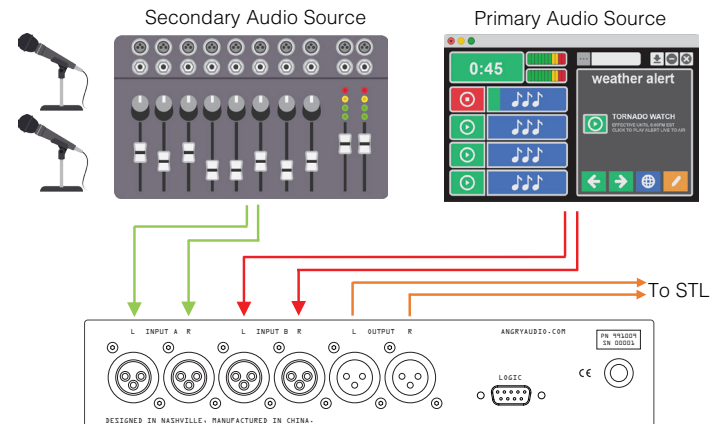

## Buttons, knobs, switches, lights, and connections.

Or, "What happens if I push this button?":

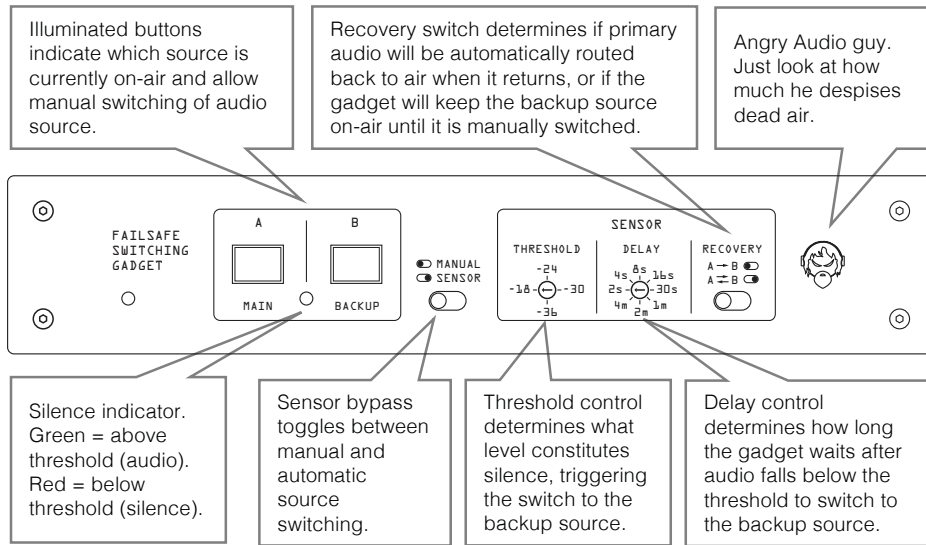

And a look at the back panel:

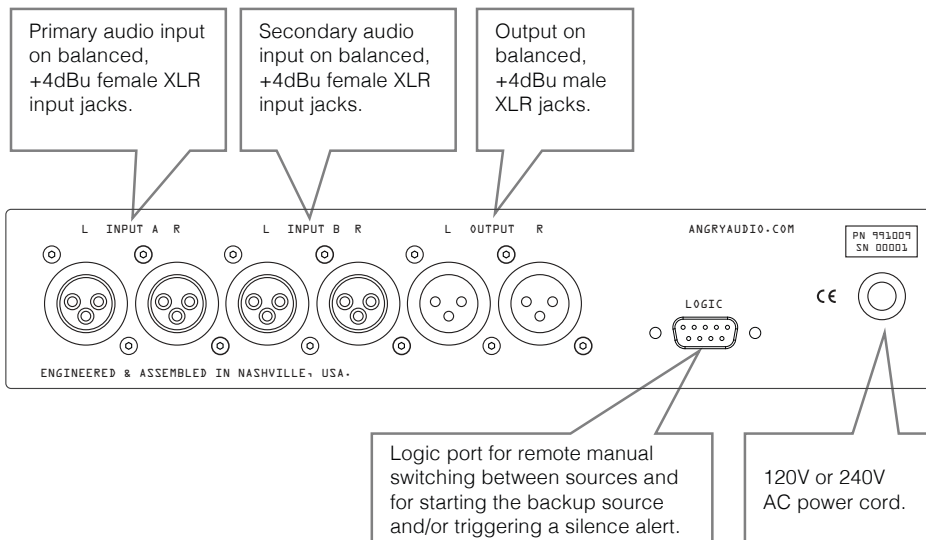

## Connecting to the outside world.

The 9-pin DSUB connector on the rear panel of the Failsafe Gadget serves as a handy logic port for manually switching between the A and B audio sources remotely, and for starting the the backup audio source or triggering a silence alert.

The pin-outs are as follows:

- |                             |            |
|-----------------------------|------------|
| 1: Common                   | 6: Relay B |
| 2: Remote A (Main Source)   | 7: Relay C |
| 3: Remote B (Backup Source) | 8: Relay A |
| 4: No connection            | 9: Common  |
| 5: No connection            |            |

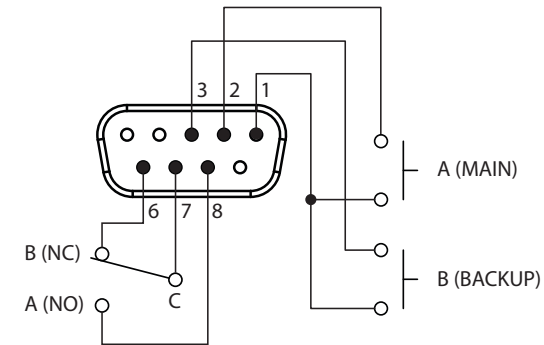

A momentary contact closure to ground via a pushbutton can remotely switch between the A and B sources, which exactly mimics the front panel buttons. To select A, short Pin 2 to Pin 1. To select B, short Pin 3 to Pin 1. An open collector to ground or relay contact to ground will also activate these inputs.

Dry relay contacts provide A/B switch status. If source A is active, Pin 8 will be shorted to Pin 7. If source B is active, Pin 6 will be shorted to Pin 7. Please note this relay is intended to switch small logic signals; never connect the logic port to AC mains power.

If soldering or crimping pins for a DSUB connector makes you nervous or sad, we've included a DB9M to RJ45F adapter in the box for the convenience of wiring with CAT5/6 cable. Happy now?

## A closer look at the pendulum and chimes.

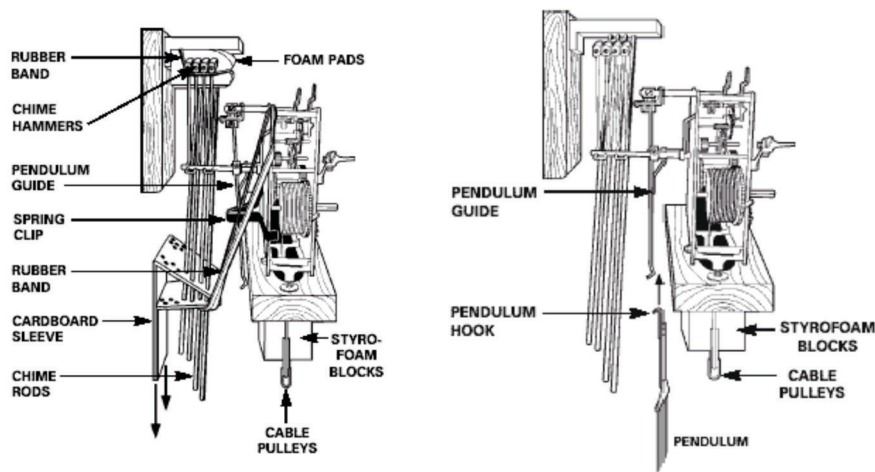

## Whoops - we totally thought you said CLOCK diagram. Let's try again.

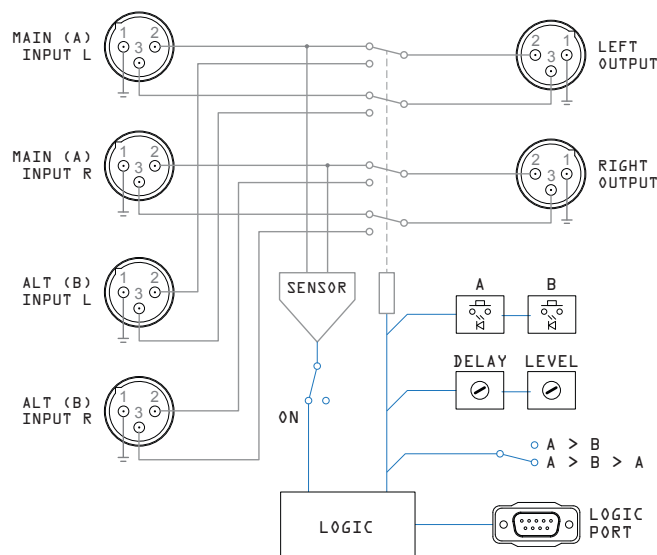

FAILSAFE GADGET FUNCTIONAL BLOCK DIAGRAM

## Riveting data about your gadget.

### Part Numbers

Failsafe Gadget (115VAC, US plug)	Part No. 991009
Failsafe Gadget (230VAC, Europe plug)	Part No. 991009E
Failsafe Gadget (230VAC, Australia plug)	Part No. 991009A
Failsafe Gadget (230VAC, UK plug)	Part No. 991009U

### A/B Pushbutton Switches

Momentary action, LED illuminated

### Connections

Inputs A & B	Female +4dBu balanced XLR
Output	Male +4dBu balanced XLR
Logic Port	Female DB-9 Sub

### Power and Environmental

North American Config.	115VAC 60Hz, NEMA 5-15P power plug
Export Versions	230VAC 50/60Hz, various plugs
Power Consumption	4VAC
Operating Temperature	0° to 40° C (32° to 104° F)
Storage Temperature	-20° to 45° C (-4° to 113° F)
Relative Humidity	0% to 90% non-condensing
Cooling	Vented chassis (fanless)

### Product Weight & Dimensions

Width x depth x height	8.5 x 6.25 x 1.70 in., 21.6 x 16 x 4.32 cm.
Weight	3.5 pounds, 1.6 kilograms

### Shipping Weight & Dimensions

Length x width x height	12 x 9 x 6 in., 31 x 23 x 16 cm.
Weight	5 pounds, 2.3 kilograms

### Box includes:

- Failsafe Gadget
- 2x Dual XLRM to RJ45F (StudioHub) adapters
- 1x Dual XLRF to RJ45F (StudioHub) adapters
- DB9F to RJ45F adapter for logic port

## In The U.S.

In the U.S., this gadget complies with the limits for a Class A computer device as specified by FCC Rules, Part 15, Subpart J, which are designed to provide reasonable protection against such interference when this type of equipment is operated in a commercial environment.

## In Canada

In Canada, this gadget does not exceed the Class A limits for radio noise emissions set out in the Radio Interference Regulations of the Canadian Department of Communications.

## In Europe

This gadget complies with the requirements of the EEC Council Directives 93/68/EEC (CE Marking), 73/23/EEC (safety – low voltage directive), and 89/336/EEC (electromagnetic compatibility). Conformity is declared to standards EN50081-1 and EN50082-1

## Well, that was poor planning.

So how about about some tic-tac-toe?

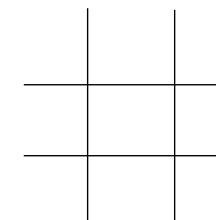
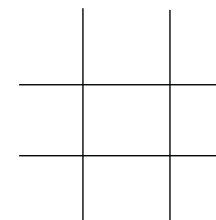
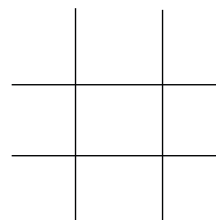

Or a word search?

```

Y K V M Q D R A T W
E D Q U O E G S W K
A N G R Y A U D I O
J Q Q P Y D N A H G
P N C H O A A Q A U
P V V Y R I X D F D
V K H S P R G O D O
I U I L J E A V H N
P B V A T N H G S R
A B S W I T C H S W
    
```

ABSWITCH ANGRYAUDIO DEADAIR GADGET HANDY MURPHYSLAW

Draw a pretty picture!



Where the electrons go inside the Failsafe Gadget.

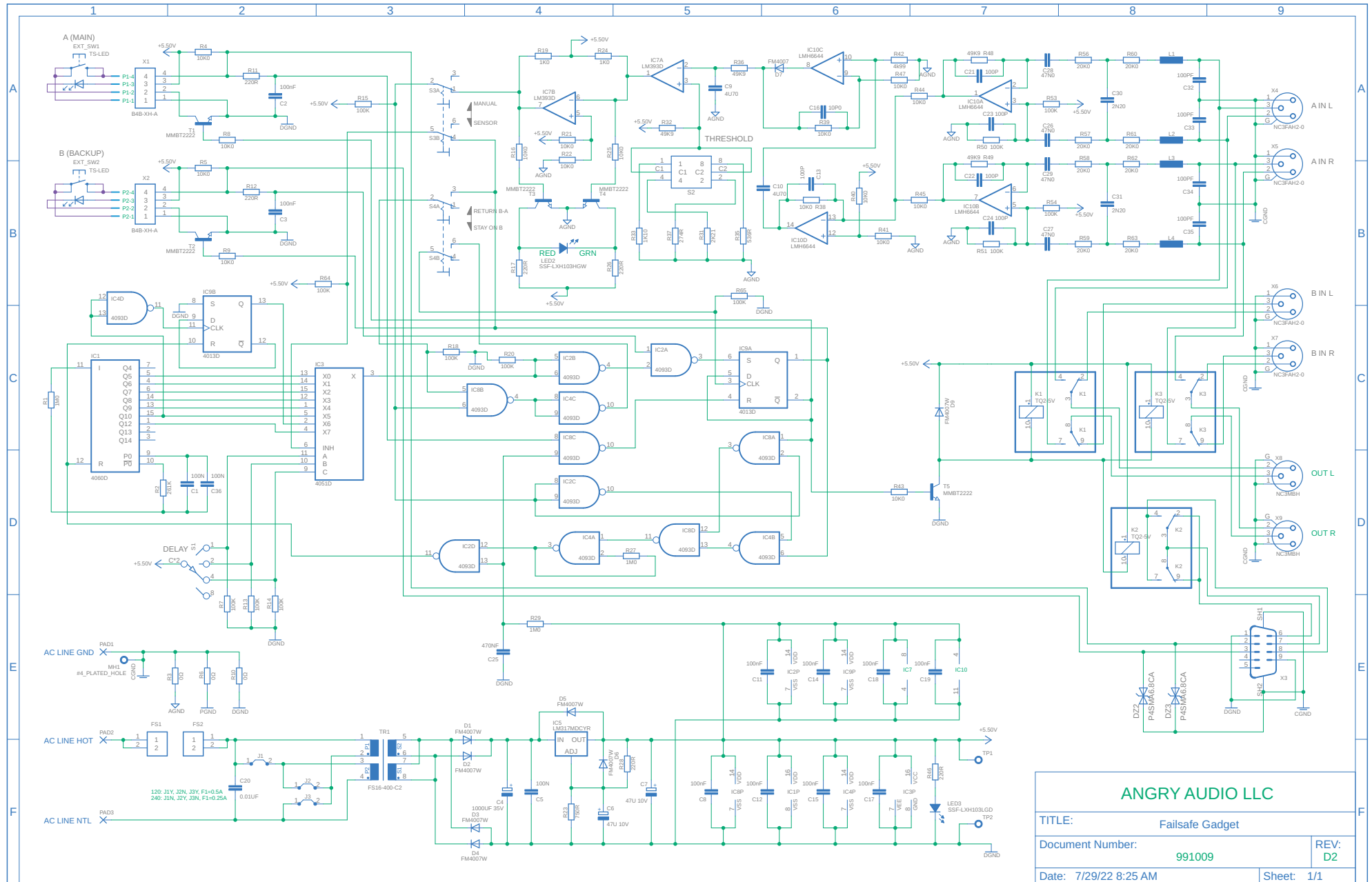

<b>ANGRY AUDIO LLC</b>		
TITLE: Failsafe Gadget		
Document Number:	991009	REV: D2
Date: 7/29/22 8:25 AM	Sheet: 1/1	