

The volume you crave

# HEADPHONE GIZMO



[angryaudio.com](http://angryaudio.com)

# A headphone amplifier so loud you may not need a transmitter.

## Headphone Gizmo

Radio jocks love loud headphones. Maybe they expect to hear everything with the phones around their necks. Maybe they want to watch the cans jumping to the beat. No matter the reasons, the Headphone Gizmo will give them all the volume they crave. And if your talent prefers to hear all the detail and nuance in their headphones, the precision analog circuitry in the Headphone Gizmo is as transparent as it is loud.



Headphone Gizmos mount to the underside of your counter to save desktop space, always right where they're needed and never in the way. The low-profile design has contoured edges to prevent painful knee incursions. Both 1/4 inch and 1/8 inch jacks are provided. Whether your talent uses full coverage phones or modern IEMs, the Headphone Gizmo will drive them to perfection.

Feed the Headphone Gizmo stereo audio via its RJ-45 input connector (StudioHub+ format) from your node or blade output. Adapters are available for most audio connector types. A convenient daisy-chain output passes the signal along to the next device. Power the Headphone Gizmo from a StudioHub+ power supply inserter or the included wall adapter.

The Headphone Gizmo is available in two versions, one with a local volume control and the other with fixed gain. Like all Angry Audio products, the Headphone Gizmo is built for the rigors of radio with its powder-coated steel enclosure, premium components, and RFI-immune circuitry. It will sound amazing for years.

You can't be too rich, too thin or — if you're a headphone amp — too loud. One announcer told us he wanted to watch the cans jumping to the beat of the music when they were sitting on the countertop. We hope he was exaggerating. But hey, we listened. And we engineered the Headphone Gizmo to deliver headphone audio so loud and so clean that the most demanding jocks will love it. Even yours.



# Headphone Gizmo

Most headphone amps are optimized for either a high or low load impedance. The Headphone Gizmo circuitry has no such limitations. It is capable of the high currents needed by low impedance phones. While also comfortably delivering the high voltages your high impedance cans demand. No matter what you plug in, the Headphone Gizmo will never run out of loud, clean power.

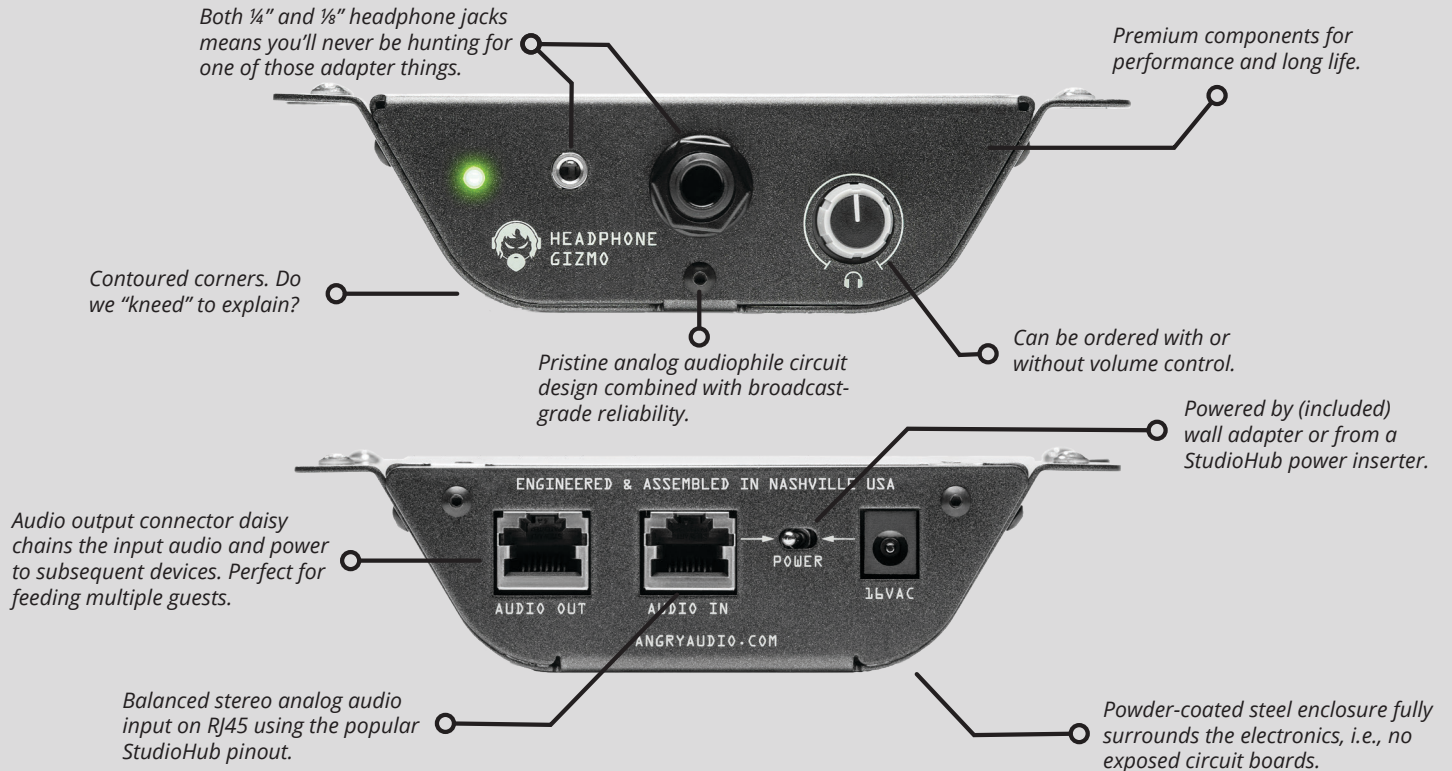

## Specifications:

### Connections

Audio Input and Output  
Headphone Outputs  
Power

RJ45 jack, StudioHub+ format  
1/8" (3.5mm) and 1/4" (6.3mm) TRS  
16VAC (115V or 230V) via wall adapter  
or +/-15VDC via RJ45 audio input jack

### Headphone Amplifier

Nominal Input Level +4dBu  
Maximum Input Level +26dBu  
Input Impedance 20kΩ Fully Balanced  
Headphone Impedance  $\geq 16\Omega$   
Output Voltage +20dBu  
Output Power 2.6W per channel at 16Ω  
Output Current 400mA  
Frequency Response 20Hz - 20kHz  $\pm 0.1$ dB  
THD+N  $\leq 0.003\%$  (20Hz - 20kHz)  
Noise  $\leq -96$ dBu (20Hz - 20kHz unweighted)  
Dynamic Range  $\geq 115$ dB  
CMRR  $\geq 80$ dB (1kHz)

### Power and Environmental

Power Input (120V Adapter) 120VAC 60Hz  
Power Input (230V Adapter) 230VAC 50Hz  
Power Output (Adapter) 16VAC, 500mA, 8.0W  
Operating Temperature 0° to 40° C (32° to 104° F)  
Storage Temperature -20° to 45° C (-4° to 113° F)  
Relative Humidity 0% to 90% non-condensing

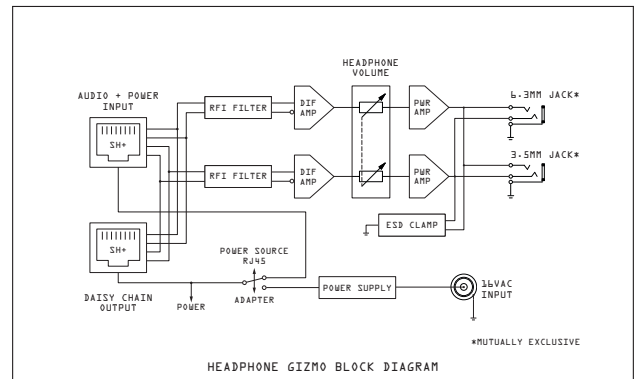

**Part number:** 991030 115VAC USA Power Plug  
991030E 230VAC Europe Power Plug  
991030A 230VAC Australia Power Plug  
991030U 230VAC UK Power Plug

### Product Weight & Dimensions

Gizmo Dimension 5.6in x 4.0in x 1.4in  
Shipping Dimensions 8.0in x 6.0in x 3.0in  
Shipping Weight 3.0 pounds

### Box Includes:

Headphone Gizmo  
Wall adapter power transformer



### Balancing Gadgets

All three Balancing Gadgets feature an internal low-noise linear power supply, direct coupled transformerless analog circuitry and our exclusive input design that suppresses common mode noise. The result is the most sonically-transparent devices available. Never any buzz, hum, hiss or RFI.



### Bluetooth Gadget

Bidirectional smartphone to PRO audio interface. Use your Bluetooth-equipped device for audio playback, phone calls, skype, etc. AAC and APTX audio codecs provide premium audio quality.



### Talkshow Gadget

Adds broadcast features to audio mixers. Monitor speaker muting and volume control, pushbutton microphone control, on-air warning logic. All passive signal chain features sealed gold-contact relays.



### Fail-safe Gadget

Stereo silence sensor and backup audio switcher. Adjustable threshold and delay. Alarm logic port. Can also be used to switch when audio is active.



### Distribution Gadget

2x4 stereo or 2x8 monaural analog audio distribution amplifier. Choose from IHF or PRO audio input. Each output pair can be stereo or mono sum.



### Guest Gizmo

Stereo headphone amplifier, Cough (mute) button, tally lamp driver. Installs in desktop. High power headphone amplifier can drive high or low impedance headphones.



### Mic Tally Gizmo

Driver for MIKA mic arms equipped with LED tally. Installs in desktop. Dual logic inputs to illuminate tally either red or white.



### Headphone Gizmo

Premium stereo headphone amplifier with StudioHub RJ45 connectors for input and daisy-chain output. Innovative circuitry can drive high impedance or low impedance headphones with power to spare.

# ANGRY AUDIO LLC

128 Holiday Court, Suite 118  
Franklin TN 37067 USA

+1 (615) 763-3033  
www.AngryAudio.com  
answers@angryaudio.com